

Automotive Grade Radial Lead MLCCs



Feature

- * Automotive grade high reliability.
- * Excellent solderability and heat resistance for reflow soldering.
- * Epoxy resin encapsulated for excellent moisture resistance, mechanical strength and heat resistance.

Application

- * AEC-Q200
- Has passed the AEC - Q200 standards set all of the experimental conditions.

Part Number

ACC4	0805	N	331	K	500	T	F1
A	B	C	D	E	F	G	H

A:

Product Type	
Code	Type
ACC4)) Class Dielectric Radial Leaded Mlcc (Automotive Grade)
ACT4)) Class Dielectric Radial Leaded Mlcc (Automotive Grade)

B:

UNIT: INCHES

x Nominal Body Size (Length x Width)	
0805	0.17x0.15
1206	0.20x0.18

C:

Temperature Characteristics			
CG(N)	COG(NP0)	0± 30ppm/°C	-55~+125
B	X7R	± 15%	-55~+125

D

Nominal Capacitance
<p>First two digits are significant, and the third digit is number of zeros .</p> <p>For example:</p> <p>104=100000pF</p> <p>5R6=5.6pF</p>

E

Tolerance					
C	D	G	J	K	M
±0.25pF	±0.5pF	±2.0%	±5.0%	±10%	±20%
C.D C 10PF C.D for C 10PF NP0:C.D.G.J.K.M, X7R:K.M.					

F

Rated Voltage
<p>First two digits are significant , and the third digit is number of zeros .</p> <p>For example:</p> <p>500=50V, 101=100V</p>

G

Packaging Style		
Tape	P	Ammo
	T	Reel
Bulk	Blank	

H

mm	
Lead Space (Unit: mm)	
F1	2.54
F3	5.08

Size code, capacitance and voltage

Reliability Test Method

Item	Technical Specification		Test Method and Remarks		
Capacitance (C)	I Class I	within the specified tolerance.	Capacitance	Measuring Frequency	Measuring Voltage
			C 1000pF	1MHZ±10%	1.0±0.2V
	C 1000 pF	1KHZ±10%			
	II Class II	within the specified tolerance.	Capacitance	Measuring Frequency	Measuring Voltage
C 10uF	1KHZ±10%	1.0±0.2V			
Dissipation Factor (DF)	I Class I	C 50pF DF 0.15% C 50pF DF 1.5[(150/C)+7] X10 ⁻⁴	Capacitance	Measuring Frequency	Measuring Voltage
			1000pF	1MHZ±10%	1.0±0.2V
			1000 pF	1KHZ±10%	
	II Class II	B	DF 3.5%	Capacitance	Measuring Frequency
C 10uF			1KHZ±10%	1.0±0.2V	
Insulation Resistance	I Class I	C 10nF IR 10000M C>10nF R.C 100 F	: Measuring Voltage: Rated Voltage : 60± 5 Duration: 60±5s 75%		
	II Class II	C 25nF IR 4000M C>25nF R.C 100 F	Test Humidity: 75% 25 ± 3 Test Temperature: 25 ± 3 50mA Test Current: 50mA		

Item	Technical Specification	Test Method and Remarks
Biased Humidity	C/C C0G: $\pm 2.5\%$ $\pm .25\text{pF}$ X7R: $\pm 12.5\%$	2 Preconditioning class 2 only 140 ~150 1 24 At 140 ~150 1 hour, then keep for 24 \pm 1 hour at room temp. 85 \pm 2 80~85%R.H. 100K 1.3~1.5V 1000 Test condition 85 ° C, 85% R.H. Add 100 K resistor, applied Ur and 1.3 to 1.5 volts for 1,000 hours.
	DF COG Cr 30pF 0.5% Cr 30pF 1/ 400+20Cr X7R 25V : 0.035 max 16V : 0.050 max 10V : 0.075 max	
	IR COG C 10nF IR 10000M C>10nF R. C 100 F X7R C 25nF IR 4000M C>25nF R.C 100 F	
	Appearance No visible damage	
Life Test	C/C C0G $\pm 3\%$ $\pm 0.3\text{pF}$ X7R $\pm 12.5\%$ C0G: $\pm 3\%$ or $\pm 0.3\text{pF}$, whichever is larger. X7R: $\pm 12.5\%$	2 1000 125 50mA 24 C0G 48 X7R Applied Voltage: 2Rated Voltage Duration: 1000h Temperature 125 Charge/ Discharge Current: 50mA max. Recovery Conditions: Room Temperature Recovery Time: 24h (C0G), or 48h (X7R)
	DF COG Cr 30pF 0.5% Cr 30pF 1/ 400+20Cr X7R 25V : 0.035 max 16V : 0.050 max 10V : 0.075	
	IR C0G C 10nF IR 10000M C>10nF R. C 100 F X7R C 25nF IR 4000M C>25nF R.C 100 F	
	Appearance: No visible damage.	

Item	Technical Specification	Test Method and Remarks
Temperature Cycle	C/C: COG $\pm 2.5\%$ $\pm 2.5\text{pF}$, X7R $\pm 10\%$ COG: $\pm 2.5\%$ or $\pm 2.5\text{pF}$, whichever is larger. X7R: $\pm 10\%$	2 1 $24\pm 1\text{h}$ Preconditioning(class 2 only):up-category temperature, 1h Recovery time: $24\pm 1\text{h}$ Initial Measurement 1000 , 4 Cycling Times: 1000 times, 1 cycle, 4 steps: $24\pm 2\text{h}$ Recovery time after test: $24\pm 2\text{h}$
	DF COG Cr 30pF 0.5% Cr 30pF 1/ 400+20Cr X7R: 0.050 max	
	IR COG C 10nF IR 10000M C>10nF R. C 100 F X7R C 25nF IR 4000M C>25nF R.C 100 F	
	Appearance: No visible damage.	
High Temperature Exposure	C/C: COG $\pm 2.5\%$ $\pm 2.5\text{pF}$, X7R $\pm 10\%$ COG: $\pm 2.5\%$ or $\pm 2.5\text{pF}$, whichever is larger. X7R: $\pm 10\%$	125 ± 2 Temperature: 125 ± 2 Voltage: without 1000 Duration: 1000h Recovery conditions: Room temperature 24 () 48 () Recovery Time: 24h (Class1) or 48h (Class2)
	DF COG Cr 30pF 0.15% Cr 30pF 1/ 400+20Cr X7R 25V : 0.035 max 16V : 0.050 max 10V : 0.075 max	
	IR: IR:Same to initial value.	
	Appearance:No visible damage.	

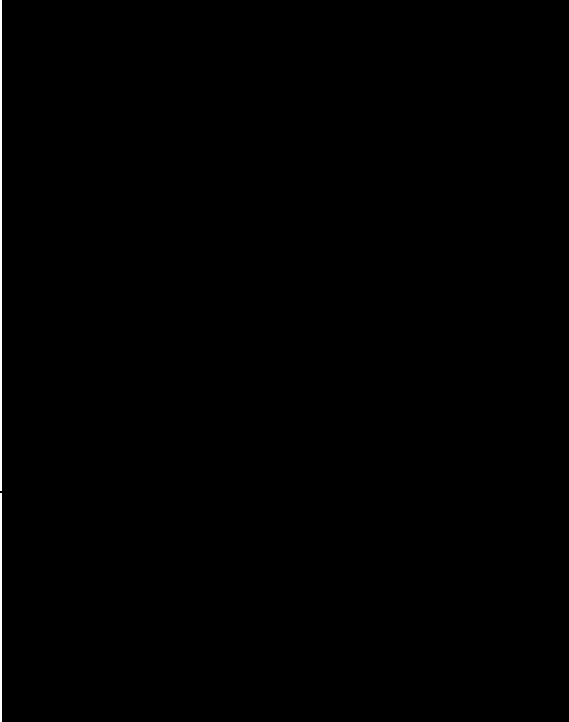
Item	Technical Specification	Test Method and Remarks
Vibration	C/C: COG $\pm 2.5\%$ $\pm 2.5\text{pF}$, X7R $\pm 10\%$ COG: $\pm 2.5\%$ or $\pm 2.5\text{pF}$, whichever is larger. X7R: $\pm 10\%$	
	DF 	
	DF COG Cr 30pF 0.15% 1/ 400+20Cr V : 0.035 max V : 0.050 max V : 0.075 max IR:Same to initial value. Qppearance:No visible damage.	3 3 (18) Three shocks in each direction shall be applied along the three mutually perpendicular axes of the test specimen (18 shocks) Waveform: Half-sin 6 Duration: 6 ms 100g Peak value: 100 g 12.3 ft/s Velocity change: 12.3 ft/s

Packaging

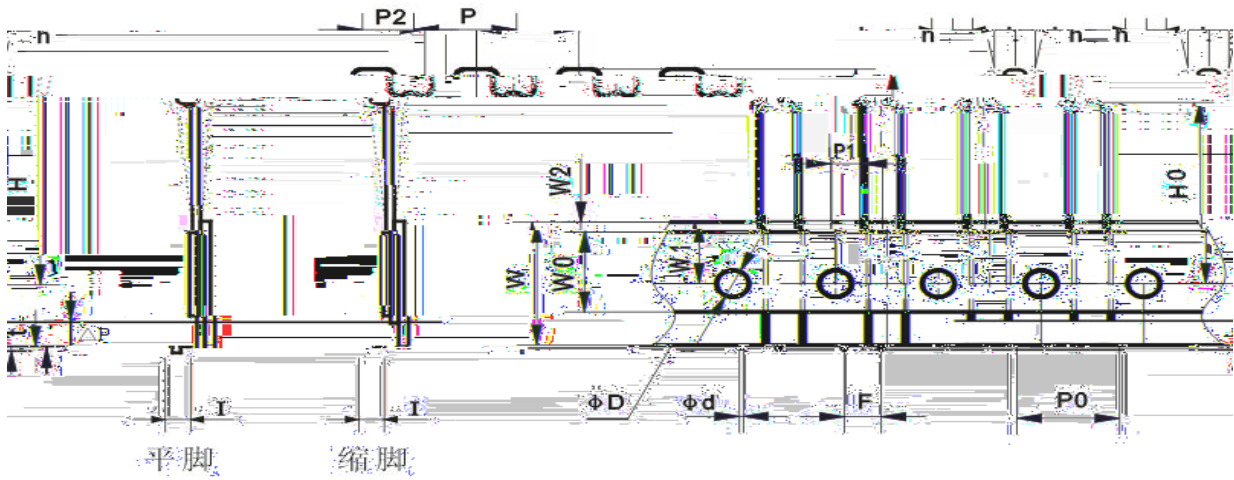

Code	P	P0	P1	P2	d	h	W	W0	W1	W2	H	H0	l	D	t	P
Dim.	12.7	12.7	3.85 5.1	6.35	0.5 0	0	18.5	8 10	9	1.5	32.25	16 19.5	1.42	4.0	0	0 P<12
Tol.	±1.0	±0.2	±0.7	±1.3	±0.1	±1.0	±1.0	±1.0	±0.5	±1.5	Max.	±1.0	Max	±0.2	Max	

* Note

P1=3.85mm for F=5.08mm P1=5.1mm for F=2.54mm.

Ammo Packaging/Tape and Reel Packaging: H0 16±1mm Pin size 7mm ;

H0 19.5±1mm Pin size 7mm .

Ammo Packaging

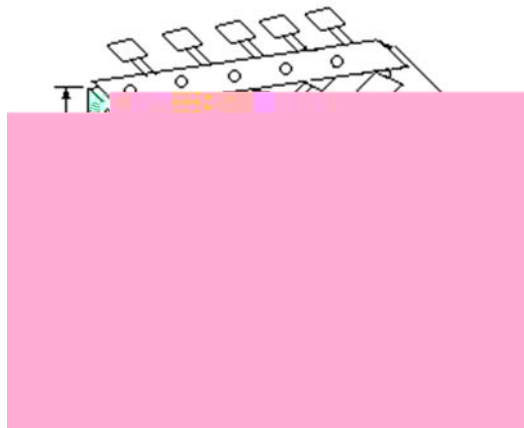

Tape and Reel Packaging

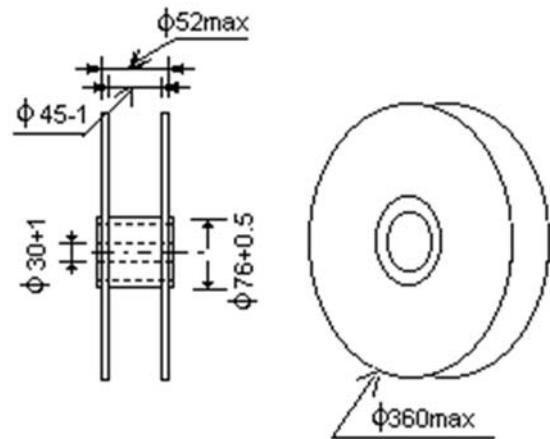

*

Packaging Quantity

Size Code	Bulk		Ammo	Tape and Reel
	pin 25mm	pin>25mm		
0805	1000pcs	500pcs	2500pcs	4000pcs
1206	1000pcs	500pcs	2500pcs	2000pcs
1209/1210	1000pcs	500pcs	2000pcs	2000pcs
1812	1000pcs	500pcs	1000pcs	1000pcs